

CTLS 2020 THE AIRPLANE.



600kg Ultralight

600kg EASA (R)TC

600kg LSA

flightdesign.com



FLIGHT DESIGN LIFTAIR®

- Designed for your Mission 3
- Our Mission 3
- Advanced Aerodynamics 4
- Land with Confidence 4
- Flight schools and Flying Clubs..... 4
- Please Fly Safely 5
- CTLS Safety Cabin 6
- Get Comfortable 7
- Avionics..... 7
- Engine Data..... 8
- Standard Equipment..... 8
- Service 8
- Structure..... 8
- Durability 9
- Travel 10
- Operating Costs..... 11
- Cockpit Options..... 12
- Graphic Designs..... 13
- Technical information 17

DESIGNED FOR YOUR MISSION

The CTLS is one of the most popular light aircraft in the world due to its great overall performance, sporty handling and class leading safety features. The new CTLS 2020 Sport Edition is now even better due to the new developments for 2020! Lighter empty weight, a new interior, redesigned cowling and Garmin G3X avionics suite are just a few of the improvements on this updated model. The flexibility of the design is evident from that fact that it can be flown as an EASA CS-LSA Restricted Type Certified aircraft, a 600 Kg Ultralight or a Compliant SLSA!

Our Mission

The CTLS 2020 incorporates evolutionary changes that make it an even better airplane for the demands of professional flight schools, flying clubs as well as private owners. It was our mission to improve the CTLS 2020's performance and reduce empty weight without sacrificing what pilots love about the CTLS. The CTLS 2020 rigid carbon fiber cockpit forming a safety cabin, plus four-point harnesses. The standard airframe emergency parachute system (AEPS) is an important addition to the list of safety features on the CTLS 2020.



The carbon/aramid fuselage on the CTLS is optimized for large internal space for the cabin and to reduce drag while providing cleaner airflow to the stabilizer. The smooth cantilever strutless wing also reduces drag and allows maximum visibility from the cockpit. Winglets improve climb, cruising range and aileron control at low speeds. The attractive new cowling and spinner improves cooling and reduces drag while improving access to the powerplant. While the top speed of the CTLS 2020 is impressively high, all CTLS fly with efficiency and low fuel consumption at all speeds.

The advanced composite main gear is extremely strong and rugged while also being flexible, absorbing over 50% of landing energy on the first rebound.

Urethane polymer shock absorbers in the nose gear give high dampening and help to smooth out hard landings.



Flight schools and Flying Clubs

The CTLS has long been popular with Flight schools and Flying clubs due to its low operating cost, easy flight characteristics and large comfortable cabin. The CTLS 2020 is now available for more training uses due to all versions approved as an EASA CS-LSA Restricted Type Certified aircraft, as a 600 Kg Ultralight and a Compliant SLSA.

The worldwide flight training industry is looking for new ways to teach more pilots at lower cost, in greater safety and with lower environmental impact. Our mission was to improve the CTLS 2020 for use by flight schools and flying clubs as well as private owners who want a sporty and easy to fly aircraft with efficiency and cruise performance for true cross-country adventures.

The Flight Design engineering staff created the CTLS with safety, performance and comfort in mind. The cockpit's carbon-aramid composite cabin helps to protect you and your passenger. The engine mount and carbon fuselage attachment points reduce the possibility of engine intrusion into the cabin area. Standard four-point harnesses along with crushable elements of the fuselage construction absorb energy and reduce possible loads to the pilot and passenger. Strong windshield uprights and massive upper construction complete the protective environment. Fuel tanks are sensibly located in the wings, well away from the pilot and passenger. Numerous improvements to the CTLS 2020 fuel system are incorporated to give proper fuel flow even in extreme conditions while maintaining the safety of the single lever operation.

The wide speed range and high structural margin of the CTLS 2020 gives you peace of mind even in the strongest conditions. Tested and certified to perform up to 600 kg (1320 pounds) with a generous safety margin, the CTLS 2020 can take you, your passenger and baggage safely as well.

The CTLS has been subjected to numerous static tests and complete flight-testing as a part of certification to major Airworthiness Standards including ASTM-FAA Light Sport Aircraft requirements, CAAC type and production certificates, EASA CS-LSA and German LTF-UL. Each CTLS is fully flight tested by our engineering test pilots and flown again after being reassembled and checked by factory trained experts in the country of destination.

Flight Design has continuously improved the CTLS since its introduction in 2008 and it has flown around the world 3 times. Flight Design used industry specialists and advanced design tools including full-scale wind tunnel testing in the Mercedes-Benz wind tunnel to further refine the aerodynamic design. Computer based flight test systems were used to develop and test the flight dynamics in a first for the Light Sport Aircraft industry. Flight Design is committed to remain the leader.

A modern aircraft should have all the safety improvements available for protecting the pilot and passenger.

in the Light Aircraft industry by employing progressive design concepts and modern safety features.

The CT first earned its German Airworthiness Certificate in 1997. The Special Light Sport Aircraft FAA Airworthiness Certificate was issued to a CTLS in April 2005. Compliance of the CT family of aircraft is verified by numerous independent design organization and production audits annually. The DGAC of India registered the CTLS. In November 2009 for India. In November 2009 the CTLS received Chinese Type Design Approval, issued for the first time ever to an LSA aircraft by the CAAC of China in combination with Production Approval. And in 2012, the CTLS received its EASA Restricted Type Certificate. Since the first flight, more than 1900 owners have loved the high cruise speed, low stall speed, and the spacious cabin of all CTs.

The CTLS is an aircraft capable of flying non-stop from NYC to Oshkosh, London to Frankfurt or Munich to Rome...flights of 1,800 km (1,000 miles). The large comfortable cabin and excellent visibility of the CTLS makes all your flights more enjoyable and a better environment for learning how to fly.

The CTLS carbon fiber cockpit has been intentionally designed following accepted design principles used in the passenger cabins of modern cars. Impact loads are transferred through the passenger area to the crush-zones at the end of the vehicle. The cabin area remains intact while the energy is absorbed in the peripheral areas. Looking at the safety cabin of the CT series you can find all important features of car design as well. The following illustration generalizes the flow of force in the CTLS:

- Forces are introduced in an impact from the engine and nose gear through the big engine mount (1) into the strong A-pillars (2) and to the center structural tunnel (5).
- The door sills (3) are designed to transport the loads backwards and into the composite sandwich shell.
- The fuselage root rib area (4) is designed as a stiff roof rail to transports the loads backwards.

- The middle of the cabin is stiffened with a structural tunnel (5) that extends from the nose gear attachment area to beyond the luggage compartment.

- The cabin is closed at the end with the main bulkhead (6) that serves together with the door sill as B-pillar. All longitudinal elements extend to and beyond this main bulkhead.

- The floor section below the seats is reinforced with 'Pyramids' (7) installed to the cabin floor, supporting the seats and stiffening the floor.

- The inner laminate of the cabin skin is made from aramid, providing the best occupant protection against splintering. The outer skin is designed as carbon fiber providing maximum stiffness and strength.

The suitability of this design has been proven in service now for over 20 years. Fleet history shows that the cabin provides a maximum of occupant protection even in a serious incident.

Real test conditions

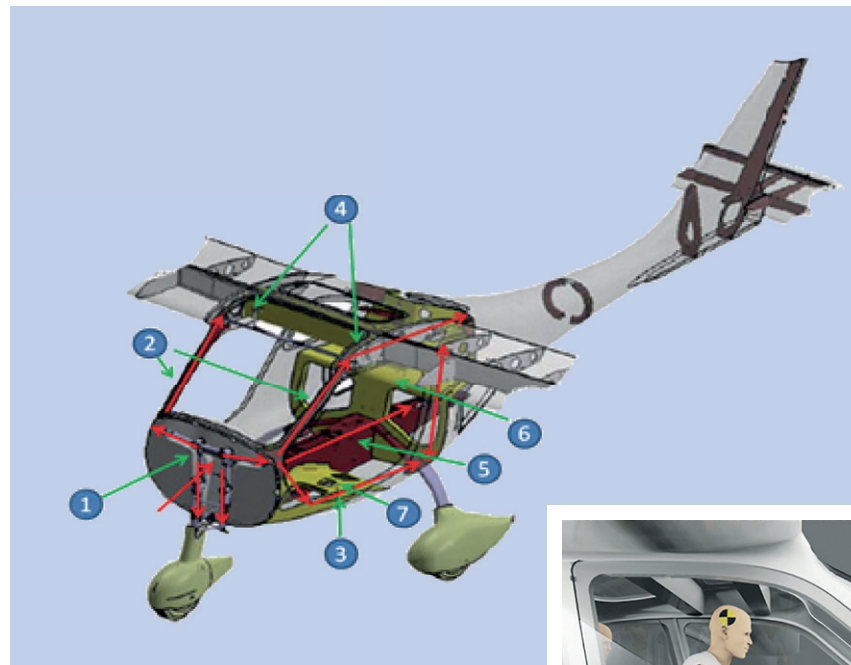

Advanced engineering

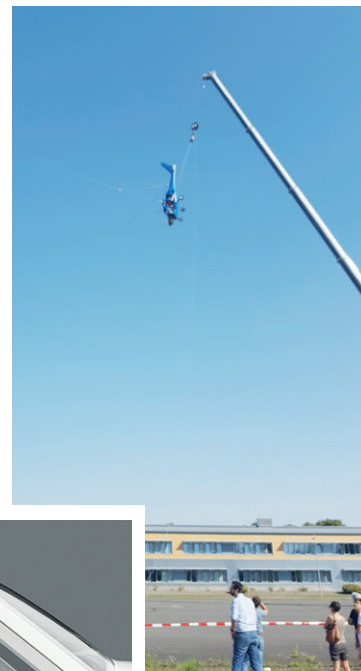

The new improved interior has added to the comfort and modern feel of the CTLS 2020. The 1.24 m (49") cabin width of the CTLS 2020 was designed to fit very tall and smaller people equally well. People with heights of 1.55 to 2.00 m (5' 1" to 6' 6") sit more comfortably than ever. Ample storage space in the cockpit is provided by a convenient jacket shelf for inflight access and big outside baggage doors give great access for bulky items stored aft of the cockpit. Two cabin windows in the rear give the cockpit an open feeling and improve rearward visibility.

Large gullwing doors held up by gas struts make entering and taking your seat easy. Three-point latches and door seals keep you secure inside. Comfortable seats with molded foam padding and pneumatically adjustable seat cushion and lumbar sections offer incomparable comfort and easy inflight adjustment in height and length.

Full dual controls and centrally located throttle quadrant are features of this ergonomically arranged cockpit. Easy-to-reach storage spaces and convenient map holders are thoughtfully provided. Standard window ventilation and cabin heating allow you to fly comfortably in all 4 seasons. The CTLS 2020 allows up to 50 kg (110 lb) of baggage to be safely stored in the dual storage compartments aft of the cabin area. If you are finding it hard to find a sport airplane that fits you, try the CTLS 2020. We think you will be pleasantly surprised.



The CTLS 2020 features some of the most advanced, yet easy to use avionics suites from Garmin and Dynon to suit your personal aviation mission. Both Garmin G3X or Dynon SkyView HDX systems feature bright high definition touch screens and synthetic vision.

The Garmin G3X system features:

Dual 10.6" G3X Touch (PFD, EMS, MAP) with Synthetic vision, wireless connectivity. Garmin GTX 335 transponder comes with Mode S and Next Gen ADSB out function. Garmin GTR 225A Com (8.33 Mhz.) and GMA 245 Intercom. Optional Garmin GFC 507™ Digital 2-axis autopilot with Level Button.

Two models-two great engine choices: CTLS 2020 Rotax™ 912S, CTLSi 2020 Rotax™ 912iS

Depending on your specific requirements and preferences, choose either the well proven Rotax 912ULS, developing a reliable 100 hp with twin carburetors, or the fuel-injected, Rotax 912iS, featuring an advanced 100 hp with the fuel/air mixture precisely computer controlled for ultra-smooth power delivery, improved high altitude performance, more useful torque, reduced CO2 emissions and improved fuel economy. The 912iS' modern fuel injection also results in surer, easier starts, lower maintenance and lower operating costs all the way to its 2000-hour TBO.

- 100-hp Rotax 912ULS with twin carburetors and 2000hrs. TBO
- Slipper clutch
- 1352 c.c. 10.5 : 1 compression ratio
- Gearbox: 2.43 : 1 reduction ratio
- Fuel: Premium unleaded auto fuel or 100 LL Avgas
- 100-hp Rotax 912iS with electric fuel injection and 2000hrs. TBO
- Slipper clutch
- 1352 c.c. 10.5 : 1 compression ratio
- Gearbox: 2.43 : 1 reduction ratio
- Fuel: Premium unleaded auto fuel or 100 LL Avgas

- Airframe parachute
- Rotax 100 HP engine
- Garmin or Dynon avionics suites
- Kannad or Artex Compact 406 MHz ELT
- Three axis trim system
- Stainless exhaust system
- Cabin heater and window ventilation
- Advanced three blade composite propeller
- Adjustable Sport seats (fore-aft & height)
- Two cockpit storage compartments
- Electric LED pre-selector flap control
- Four-point harnesses
- Two large baggage compartments
- Extra wide cabin doors with gas springs
- One-piece windshield with light green tinting
- Two wing tanks with 130 l (34 gallon) total capacity
- Composite main landing gear: 4.00 - 6" main wheels with hydraulic disc brakes,
- Steerable nose wheel 4.00 - 6"
- Fire Extinguisher and CO Detector
- 14 optional graphic patterns
- Complete document package includes: Flight, Maintenance and Parts Manual

Service

The CTLS requires only a minimum of ongoing maintenance. At our Service Centers worldwide you can have this work done by our properly trained staff. You can also participate in a two-day owner-training course at one of our Flight Design Service Centers. This course will enable you to do simple maintenance yourself supported by our detailed maintenance manual and parts manual supplied with each CTLS 2020. Our Service Center technicians are available for specialized work and repairs or to assist local mechanics on.

A new aircraft should employ modern construction techniques for many reasons. The basic maintenance of the CTLS.

Structure

The CTLS structure is made from carbon fiber construction with rigid foam core and epoxy matrix using vacuum technology. All supporting structure consists of carbon and/or aramid fibers, All materials used in the construction are from Western suppliers and correspond to either DIN or Aviation standards. The CTLS wing surfaces are post cured at 80 °C (176 °F) as it is customary in aircraft construction.

A modern airplane should be built with modern technology. Carbon fiber-epoxy aircraft construction offers unparalleled strength, durability, corrosion and fatigue-resistance. Despite high material and labor costs, carbon fiber construction is being used more widely every year.

Due to its advantages, carbon fiber construction has been incorporated in all new military and commercial aircraft replacing older aluminum & rivet construction. Repair costs with carbon fiber construction are typically far less than those for conventional metal or tube and cloth aircraft. New core foam which is now used is much more resistant to environmental damage. Repairs can be locally performed by our factory trained and approved technicians. The CTLS is finished in a durable, two-part polyurethane paint, which is very UV-resistant. Beautiful and easy to take care of, the CTLS polyurethane finish will last years when properly maintained.

The stabilizer trim tab incorporates a flexible elastic hinge, which is aerodynamically clean plus the control linkage has improved gearing for finer control and better trim feel.

In total, the aerodynamic features have significantly improved the CTLS 2020' stability, control and its overall ease of flying.

Five-axis CNC milling technology produced the metal molds for the composite main landing gear. The brake system developed together with

our partners give the correct balance of durability, performance and light weight.

and since 2008 a new foam core material is used in exposed areas to provide improved resistance a Production.

Production of the CTLS is performed by our young and highly motivated staff in Germany and Ukraine. Along with development of the original CT our own R&D and manufacturing company was created. We are constantly expanding our production capabilities to meet growing worldwide demand for our products.

With expansion into certified production authorization, we have been audited and shown compliance to ISO AS/EN 9100 at both facilities. Modern design tools such as CFD, FEA, laser scanning and production molds made with 5 axis CNC mills are now used to make components.

The balance of safety and performance is attained through rational design, well organized manufacturing and the use of dependable Western materials.

CTLS was designed and tested using the most advanced CAD programs available and these systems are also applied in production of the aircraft. We are proud to be at the vanguard of aviation technology and a leader in bringing that structural and aerodynamic technology to the light plane industry.gainst weather, fuel and chemicals.



The further you fly, the more the CTLS 2020 superiority shows. With the CTLS 2020's comfortable cabin and molded foam seats and large baggage compartments, countrywide flights become an achievable and affordable adventure! The CTLS 2020 gives you the performance and freedom to make your flying dreams a reality!

With the Dynon Mode S Class 1 transponder and a certified Dynon position source the CTLS 2020 is compliant with the FAA's ADS-B 2020 'Out' requirements and also has complete ADS-B 'In' features like Satellite based weather, traffic and real-time TFR notices.

Wherever you fly, Flight Design has engine power choices best suited to your exact requirements.

Flight schools & Photography

Remarkably slow landing speed, controllability and rugged landing gear make the CTLS the right choice. Due to its modern strutless (cantilevered) wing design and contemporary good looks, the CTLS is the right choice for Flight Schools seeking a way to attract new students. In Europe this class of aircraft has revolutionized flight training in lightplane schools.

Without a strut to block the view aerial photography is a joy. An optional 16.5 x 25.4 cm (6-1/2 x 10") photo window is available, too. With its roomy cabin and superb visibility, the CTLS is an ideal aircraft in the agricultural world for the inspection of animals and crops and other survey tasks.

* With its short field performance and rugged optional tundra gear, a careful landing for inspection is easily performed.

* Get approval from local authorities on legality of all unusual or commercial operations.

CTLS 2020 was built to get up and go. With low fuel consumption and low operating costs, you can afford to fly as much as you want.

From these seats, the remarkable visibility of CTLS 2020 will give you the feeling that you are in a helicopter with a sweeping view of the world. The well-engineered engine installation reduces airframe vibration and cabin noise.

Flight Design has been in the vanguard of the avionics revolution in light aircraft.

For flying in "hot and high" conditions, where a normally-aspirated engine will be challenged to maintain power at altitude, Flight Design offers the advantages of turbocharging with the Rotax 914t, able to maintain its 115 hp in altitude.

- 115-hp Rotax 914T with turbocharger, turbo charger control unit and 2.000hrs. TBO
- Slipper clutch
- 1211,2 c.c. 9.0 : 1 compression ratio
- Gearbox: 2.43 : 1 reduction ratio
- Fuel: Premium unleaded auto fuel or 100 LL Avgas
- PTT buttons on each control stick

CTLS was built to get up and go. With low fuel consumption and low operating costs, you can afford to fly as much as you want.

For USA customer

Hours per year	100	250	350	500	750
Total direct operating costs	\$ 34.50	\$ 34.50	\$ 34.50	\$ 34.50	\$ 34.50
Total indirect operating cost no hull insurance	\$ 42.00	\$ 16.80	\$ 12.00	\$ 8.40	\$ 5.60
Total indirect operating cost	\$ 80.75	\$ 32.30	\$ 23.07	\$ 16.15	\$ 10.77
Total operating cost including hull insurance	\$ 115.25	\$ 66.80	\$ 57.57	\$ 50.65	\$ 45.27

For Europe customer

Hours per year	100	250	350	500	750
Total direct operating costs	38.13 €	38.13 €	38.13 €	38.13 €	38.13 €
Total indirect operating cost no hull insurance	42.00 €	16.80 €	12.00 €	8.40 €	5.60 €
Total indirect operating cost	73.25 €	29.30 €	20.93 €	14.65 €	9.77 €
Total operating cost including hull insurance	111.38 €	67.43 €	59.05 €	52.78 €	47.89 €



Cockpit Options

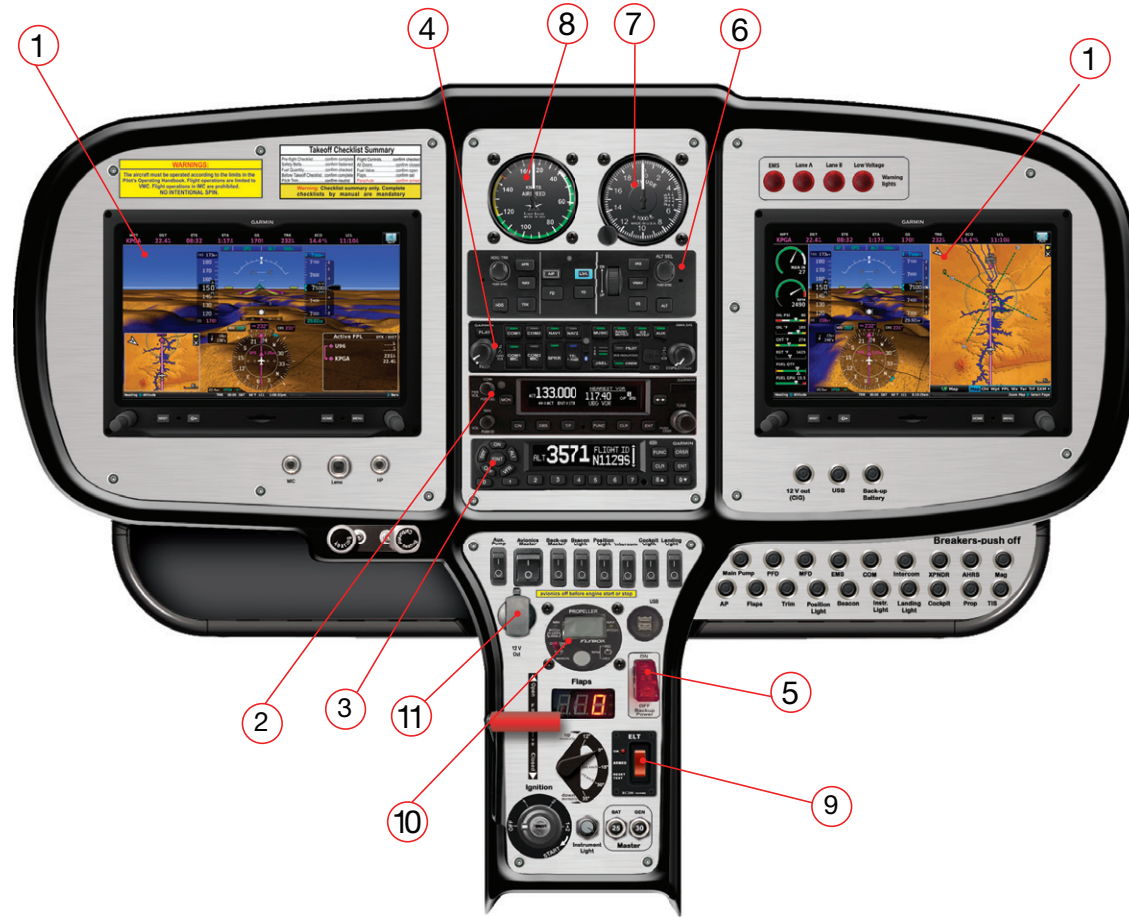

1	Garmin G3X Touch GDU 460 Screen (optional GDU 465)
2	COM Radio Garmin GTR 225A
3	Transponder Garmin GTX 335 with ADSB Out (optional GTX 345 with ADSB in/out)
4	Audio Panel Garmin GMA 245 (optional GMA 345)
5	USB socket
6	Garmin GMC 507 Digital Autopilot "mode controller panel" (optional)
7	Analogue one pointer altimeter (optional)
8	Analogue airspeed indicator (optional)
9	ELT 406 MHz remote control (KANNAD INTEGRA or ARTEX 345)
10	Constant speed controller 2 1/4"
11	12V socket

Graphic Designs

Wave 1



ORACAL 951 series		070	Black
ORACAL 951 series		209	Maize yellow
ORACAL 951 series		032	Light red
ORACAL 951 series		090	Silver grey

Wave 2



ORACAL 951 series		811	Sahara beige
ORACAL 951 series		070	Black
ORACAL 951 series		032	Light red
ORACAL 951 series		090	Silver grey

The colors reflected on the brochure are only approximations of the original colors.





Wave 4



ORACAL 951 series		811	Sahara beige
ORACAL 951 series		509	Sea blue
ORACAL 951 series		070	Black
ORACAL 951 series		093	Anthracite

Wave 5



ORACAL 951 series		026	Purple red
ORACAL 951 series		509	Sea blue
ORACAL 951 series		090	Silver grey
ORACAL 951 series		093	Anthracite

The colors reflected on the brochure are only approximations of the original colors.

CTLS 2020



ORACAL 951 series		070	Black
ORACAL 951 series		032	Light red

Jubilee Design



ORACAL 951 series		070	Black
ORACAL 951 series		090	Silver grey

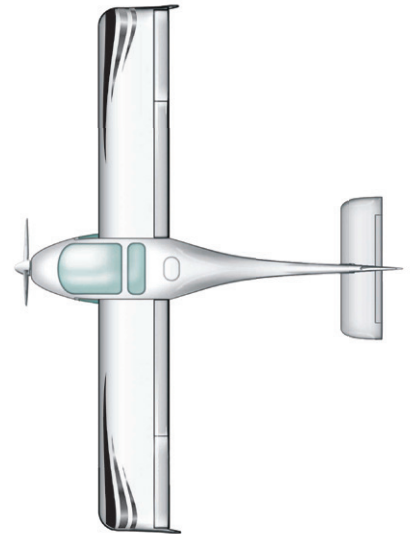

The colors reflected on the brochure are only approximations of the original colors.

Checkered Flag 1



ORACAL 951 series		070	Black
ORACAL 951 series		090	Silver grey

Checkered Flag 2



ORACAL 951 series		032	Light red
ORACAL 951 series		090	Silver grey

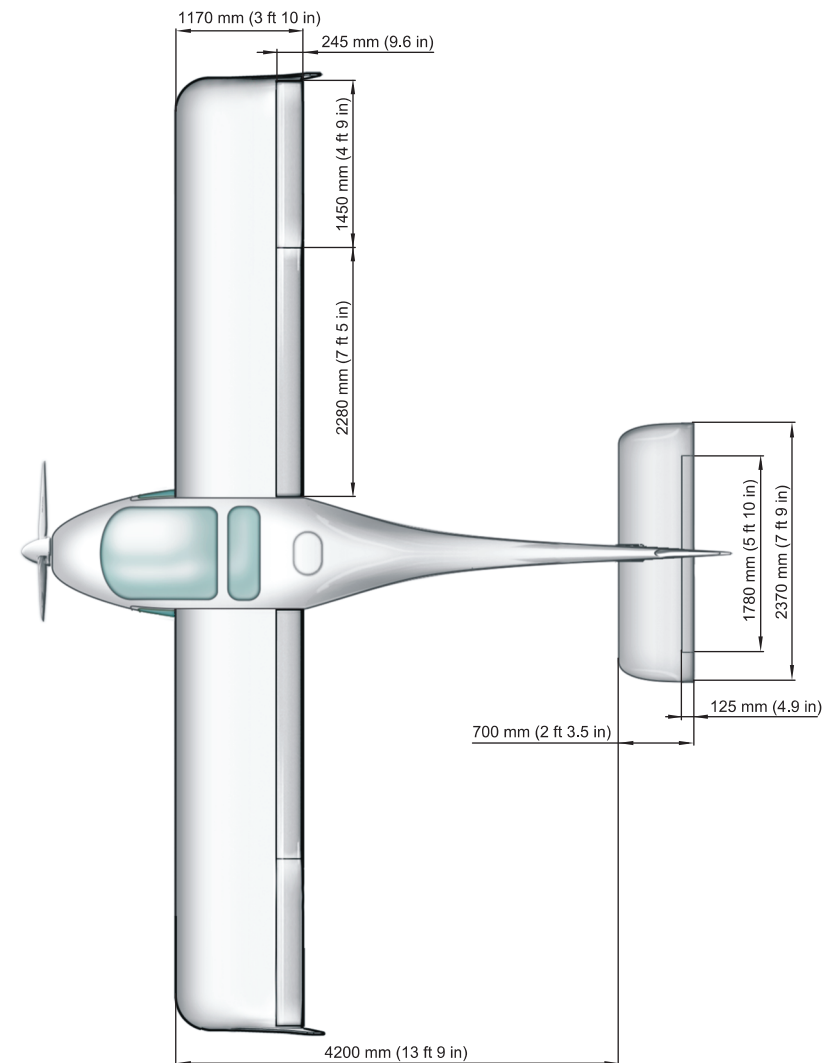
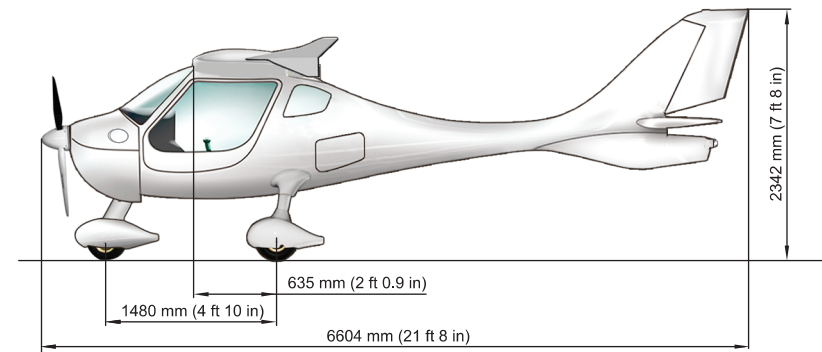

The colors reflected on the brochure are only approximations of the original colors.

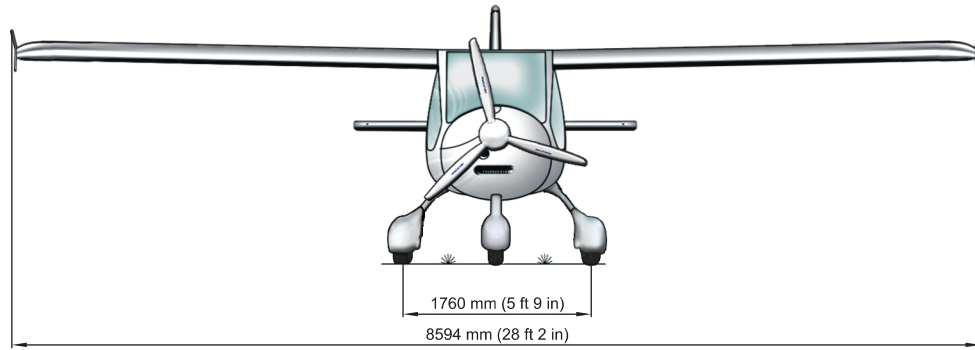

FLIGHT DESIGN general aviation GmbH
 Am Flugplatz 3
 99820 Hörselberg-Hainich
 Germany
 phone: +49 36920 7530-10
 email: info@flightdesign.com
 web: www.flightdesign.com



What is your mission?

.....

Geometry		
Max. length	6604 mm	21' 8"
Max. height	2342 mm	7' 8"
Wing span	8594 mm	28' 2"
Areas		
Wing	9.98 m ²	107.43 ft ²
Stabilator	1.60 m ²	17.20 ft ²
Vertical tail	1.41 m ²	15.16 ft ²
Aspect ratios		
Wing	7.29	
Stabilator	3.51	

Performance at MTOW

472,5 kg | 1039.5 lbs

600 kg | 1320 lbs

VH: maximum horizontal speed	240	km/h
VNE: maximum permissible airspeed (red line)	300*	km/h
Take-off run (flap +15degree)	140	m
Take-off distance over 15 m obstacle	250	m
Max. range (30 min reserve)	2000	km

240	km/h
300*	km/h
250	m
450	m
1800	km

*The never-exceed speed (VNE) demonstrated during flight testing is 300 km/h but is limited in the individual case by the ballistic recovery system installed or national regulations.

Weights and Dimensions

Typical empty weight (equipped with rescue system)	326 kg	717 lbs
Max. take-off weight	600 kg	1320 lbs
Fuel capacity	130 l	

Editorial responsibility & disclaimer
 Information given in Flight Design brochures or in other printing matter may be subject to alteration without notice. Care has been taken to ensure that the contents of this publication are accurate but FLIGHT DESIGN general aviation GmbH and its subsidiaries do not accept responsibility for errors or for information which is found to be misleading. Suggestion for or descriptions of the end use or application of products or methods of working are for information only and FLIGHT DESIGN general aviation GmbH and its subsidiaries accept no liability in respect thereof.
 Before using products supplied or manufactured by FLIGHT DESIGN general aviation GmbH or its subsidiaries, the customer should satisfy themselves of their suitability.